



Peder Stette



fish handling
with **care**





OPTIMAR

FISH HANDLING WITH CARE





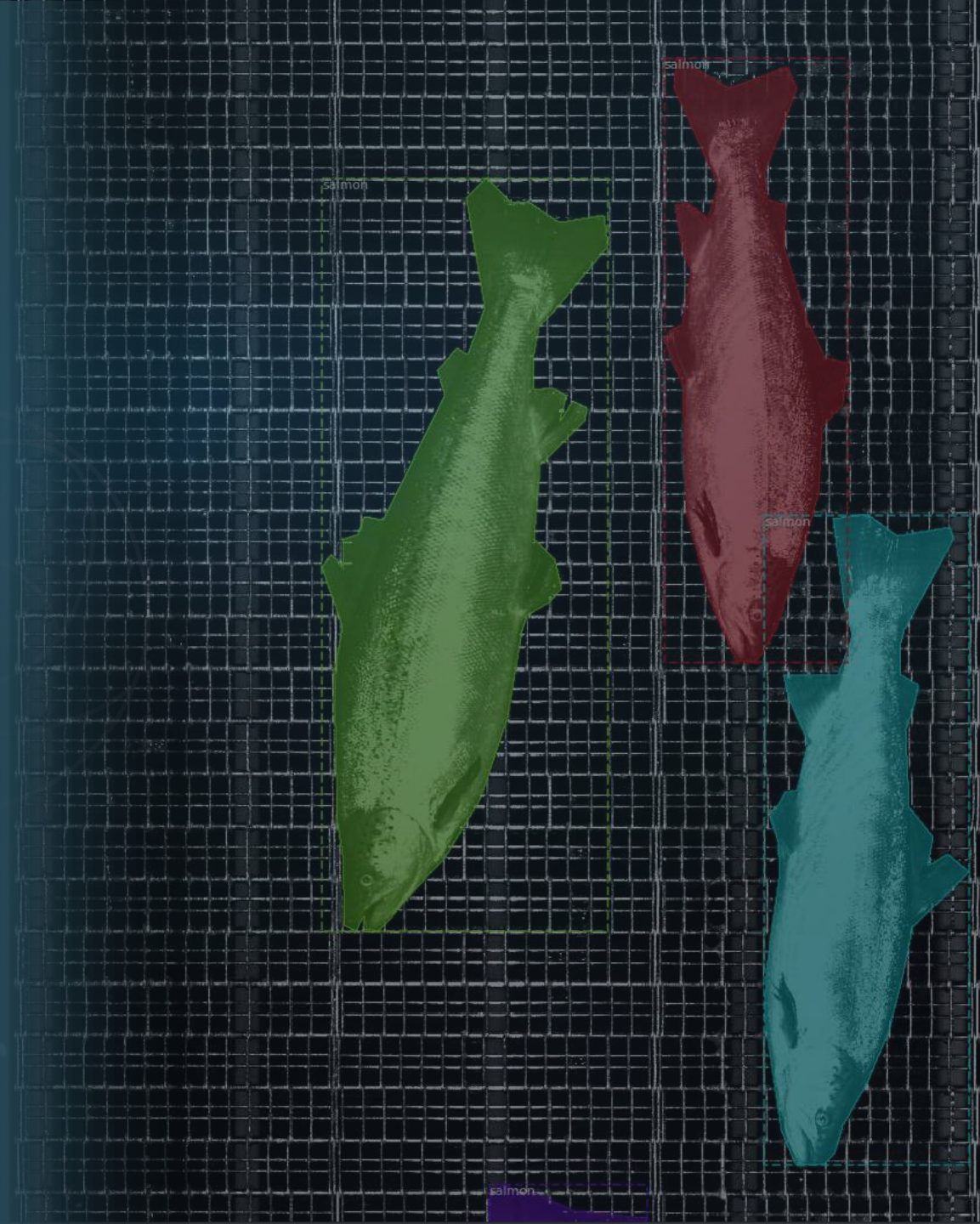

Bløgging

- Støttet av FHF (PIB)
- Klar for kalibrering og testing på levende fisk
- Kapasitet på 60 fisk/minutt pr robot
- Hvitfisk (Torsk, hyse, sei)
- Fullautomatisk bløgging gjennom gjellelokk
- Singuleringsfunksjon under utvikling







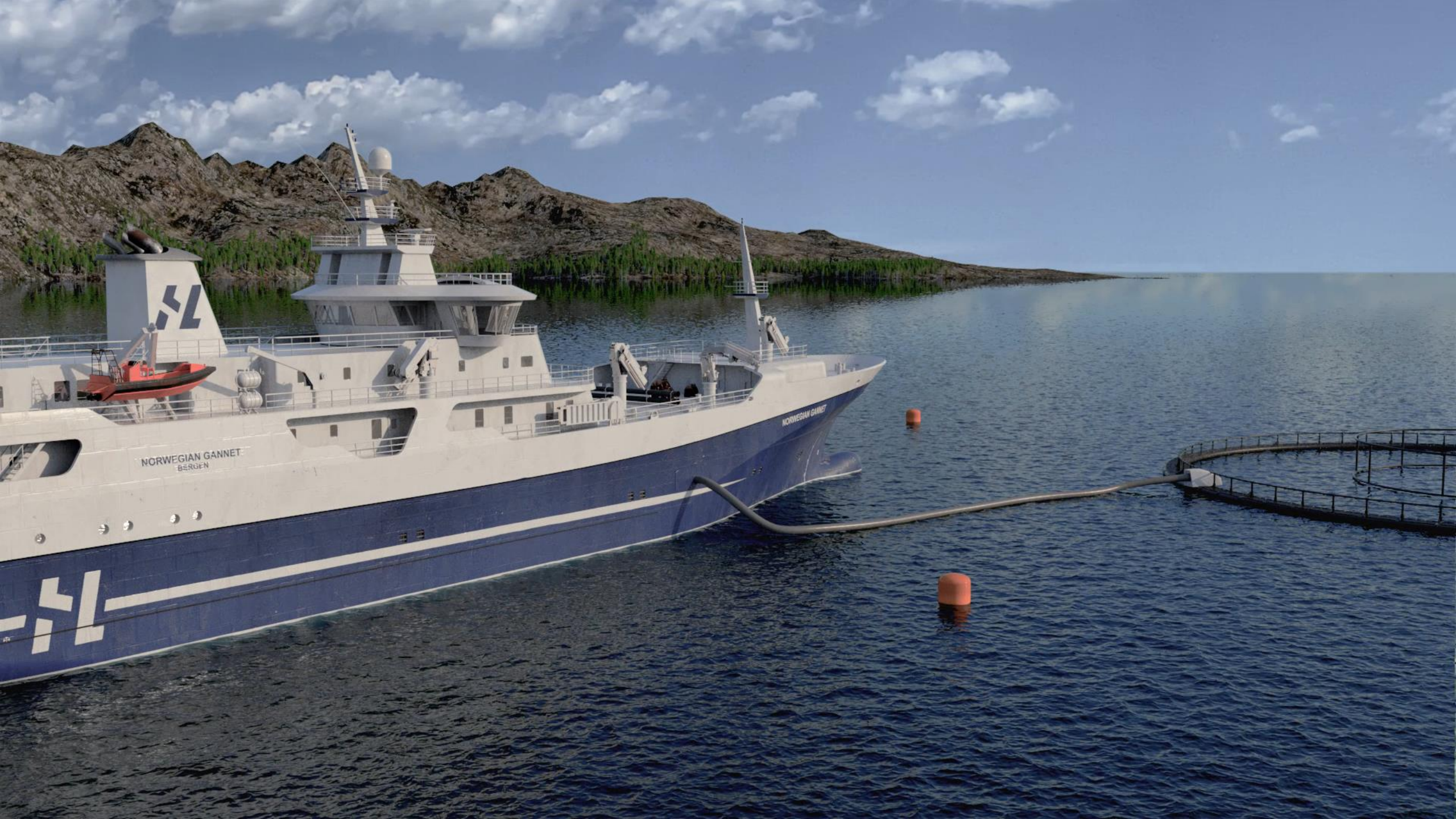

NORWEGIAN GANNET
BERGEN

NORWEGIAN GANNET

Utbløding av hvitfisk

- Bløderør med stor kapasitet
- «First in frist out» prinsippet
- Svært effektiv utbløding og nedkjøling
- Variabel utblødingstid
- Fullautomatisk inn og utmating

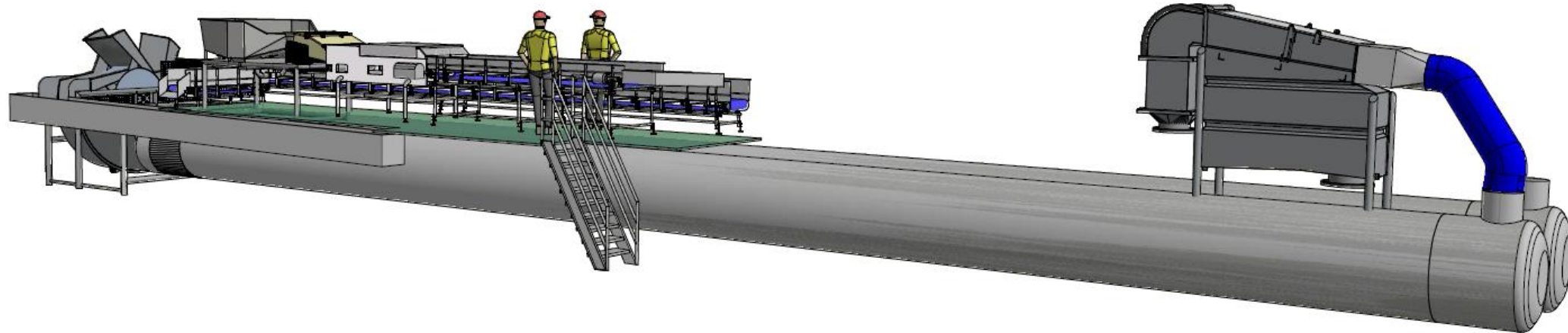
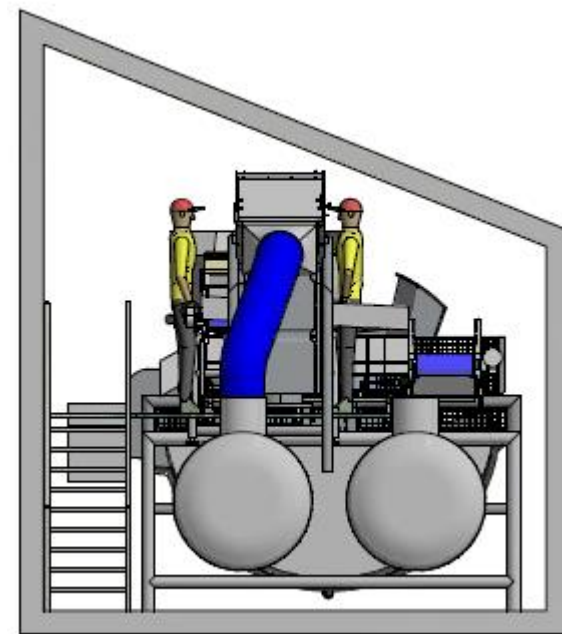

Artsgjenkjenning og størrelsesmåling



Attsortering

PLC connection status: OK!

- Enable test mode
- Save images to file
- Delay image capture
- Check if image is fish first

Line scanner 1 status: OK! Cam 1 status: OK!

Line 1

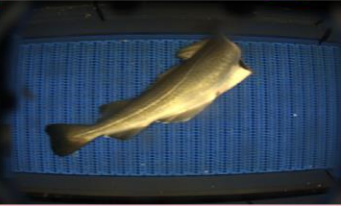

Prediction: Torsk
Prediction certainty: 1.0
Length: 0.0
Thresh. for pred.:

Line scanner 2 status: not OK! Cam 2 status: not OK!

Line 2

Prediction: Nothing yet...
Prediction certainty: 0.00
Length: 0.0

Artsgjenkjenning og størrelsessortering

- Støttet av FHF (PIB)
- Prosjektet gjennomført om bord i Granit
- Registreringa av lengde og volum
- Registrering av art
- 99% nøyaktighet på artsgjenkjenning
- Kunstig intelligens lærer kontinuerlig
- Commander visning og lagring

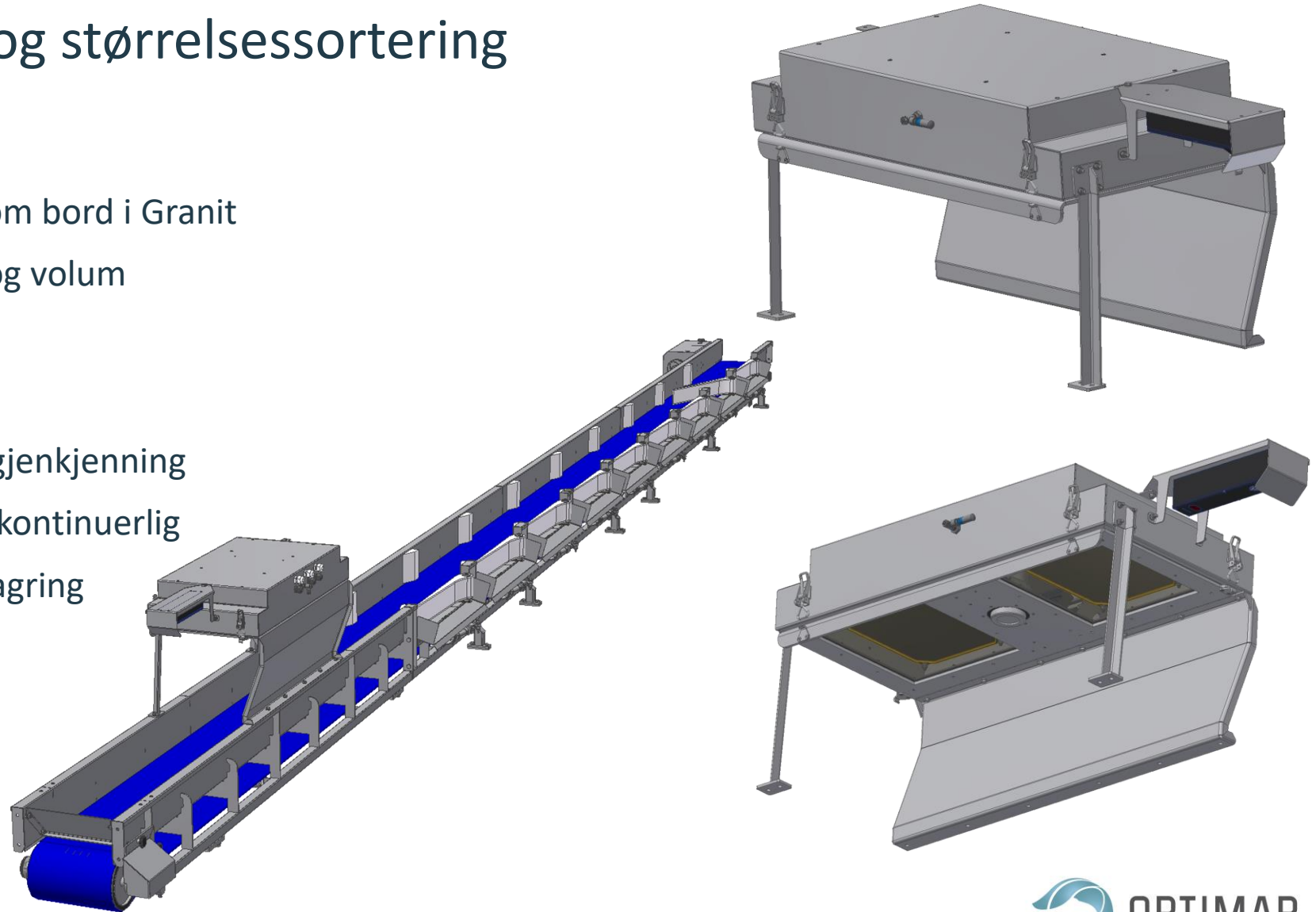

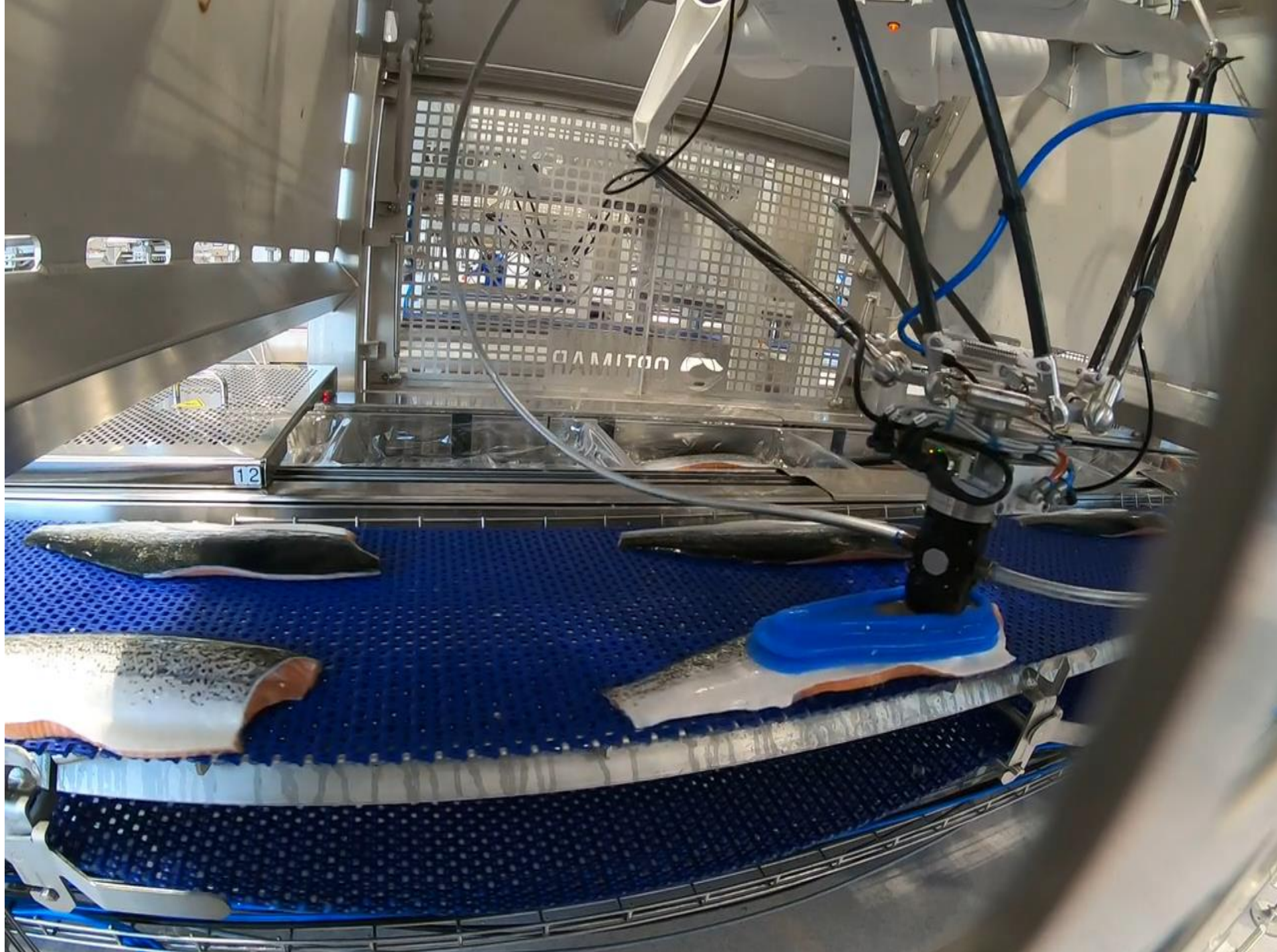

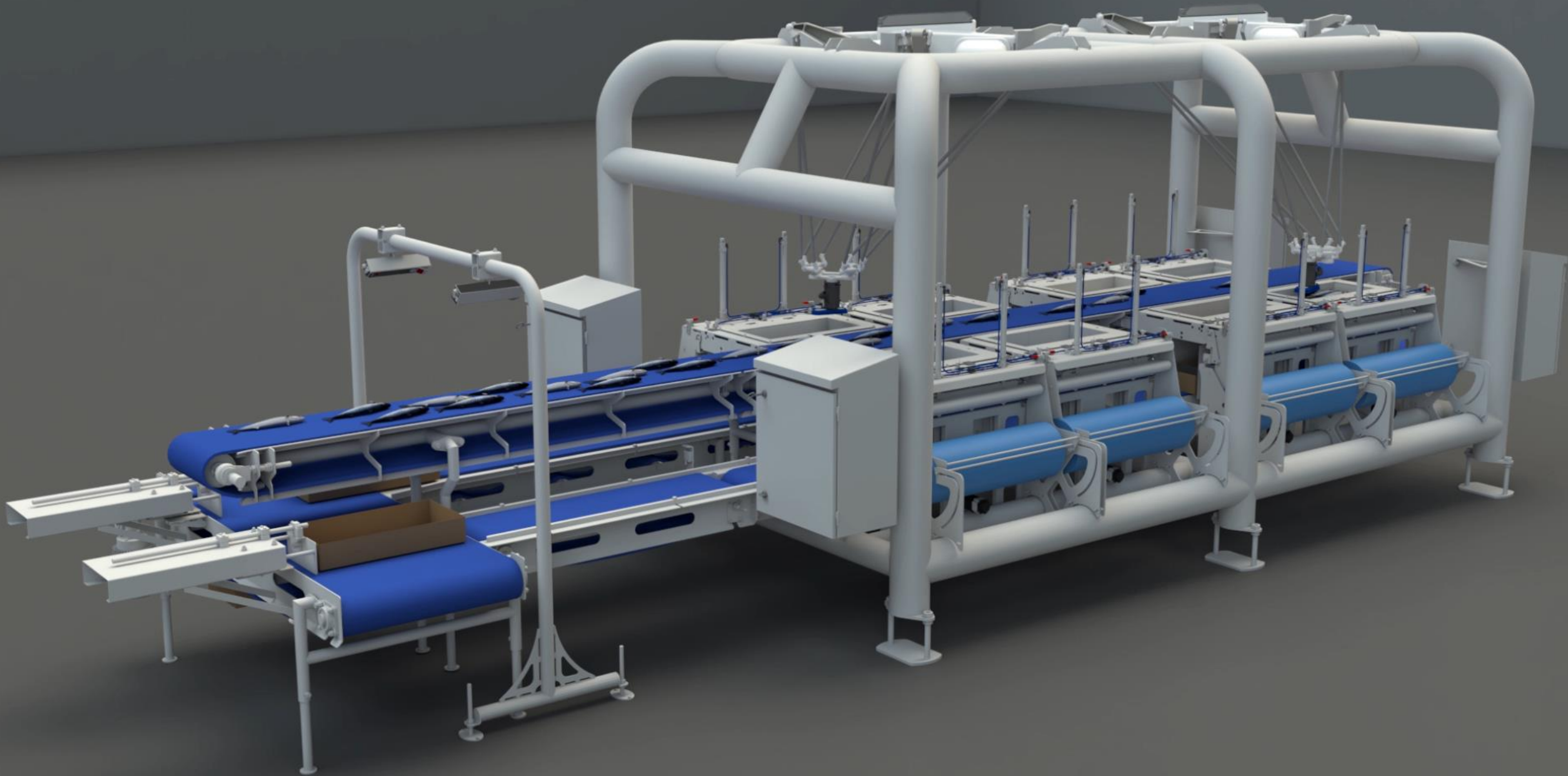

Automatisk pakkebord for filetråler

- Støttet av FHF (PIB)
 - Filetvekt beregnet fra bilde med maks 5% avvik
 - Vekt optimalisering i fryseramme på 6,8 kg
 - Automatisk rotere og plassere fileter i ramme
 - Automatisk legging av plastskillere (interleave)
 - Automatisk dsitribusjon av fryserammer
-
- Filetproduksjon blir lønnsomt for mannskapet
 - Mer biprodukt gjør mel og oljeproduksjon lønnsom
 - High End filetprodukt til makedet
 - Økt verdiskaping
 - Commander overvåkning og innsikt

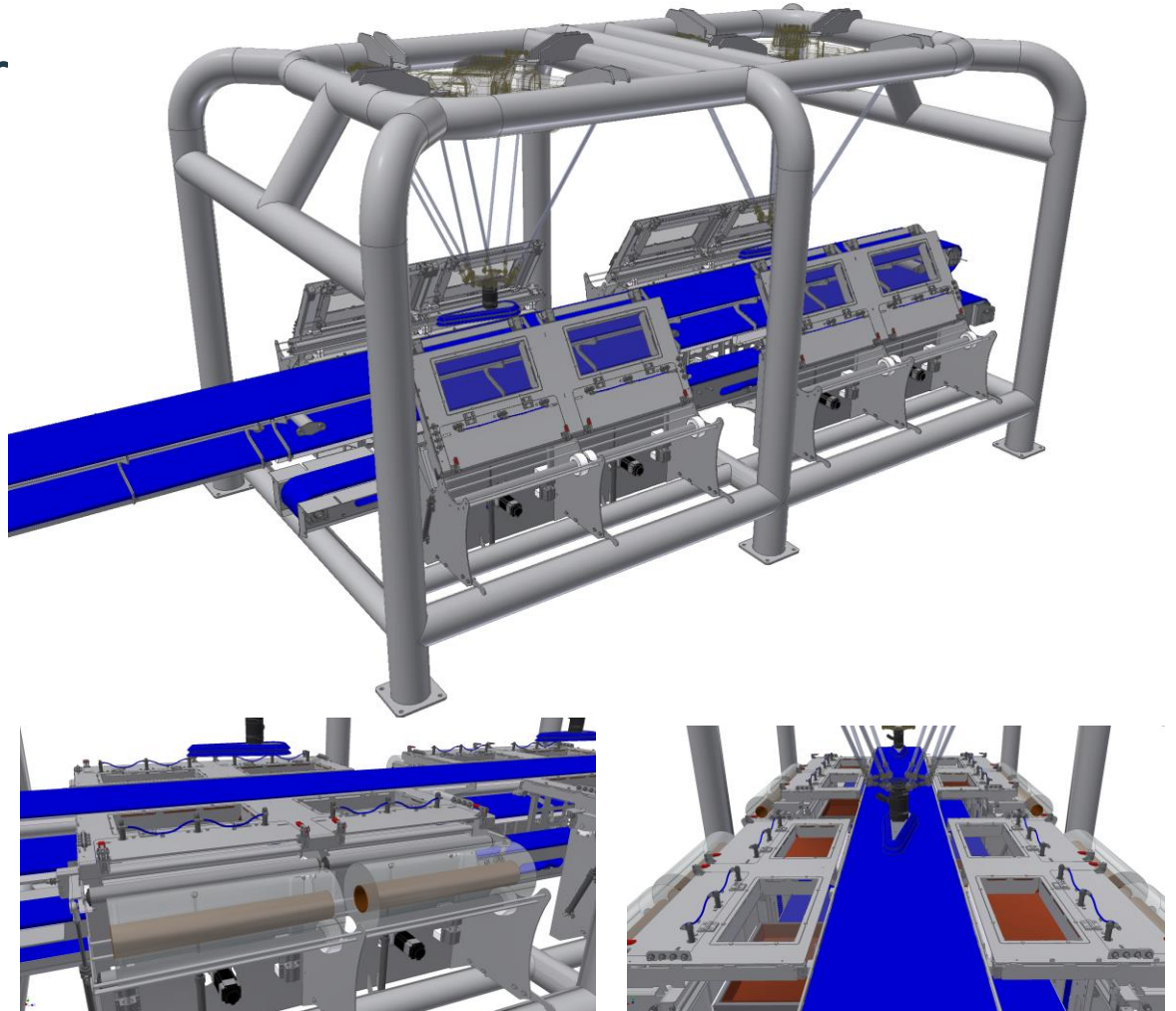

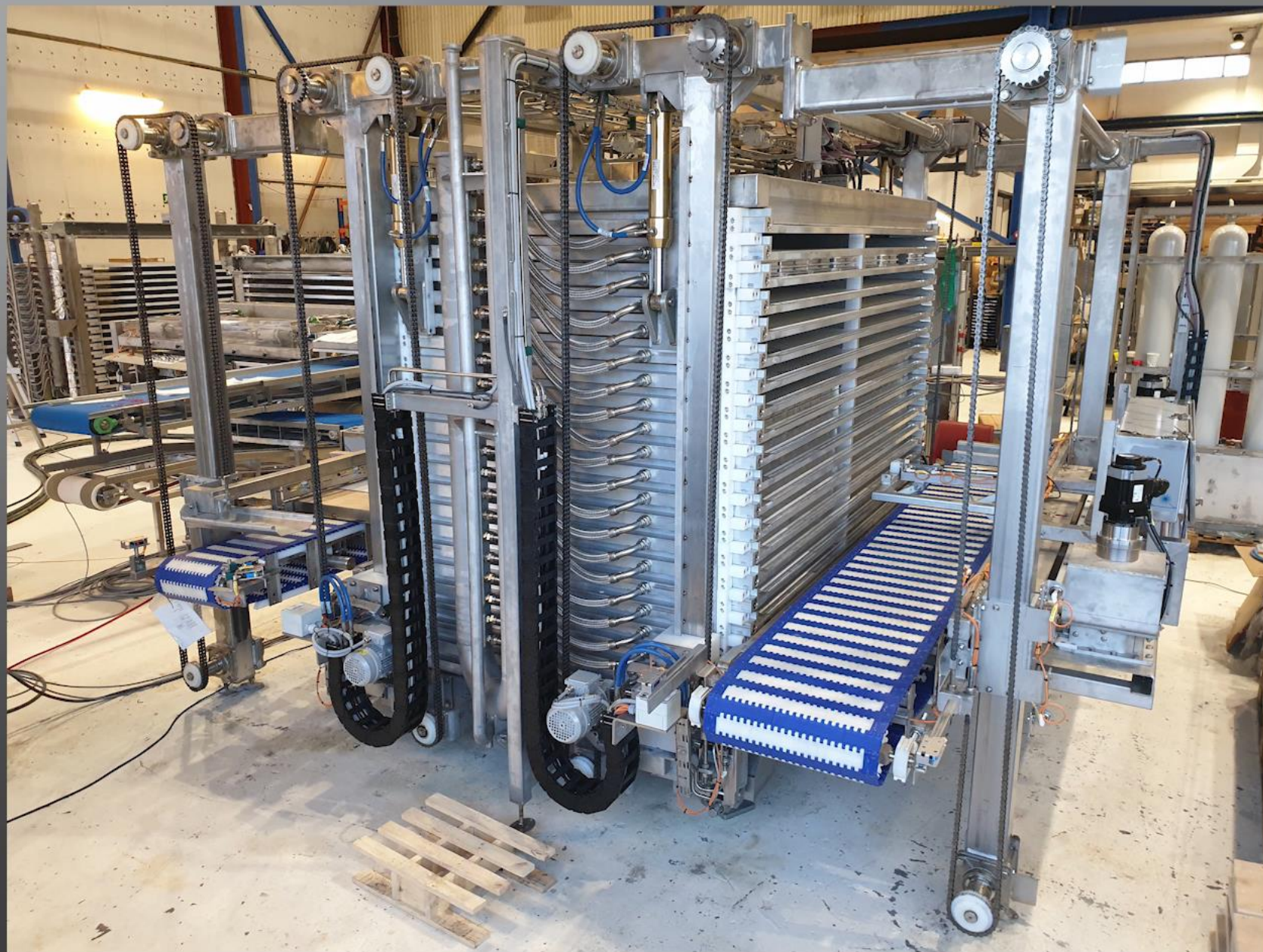

H5 Automatic horizontal plate freezer

- Kan bruke både CO2 og amoniakk
- Redusert frysetid
- Effektiv inn og utlasting
- Elektrisk drift
- Kapasitet opp til 75 tonn i døgnet
- Reduksjon av energiforbruk
- Effektiv installasjon
- Effektiv arealutnyttelse

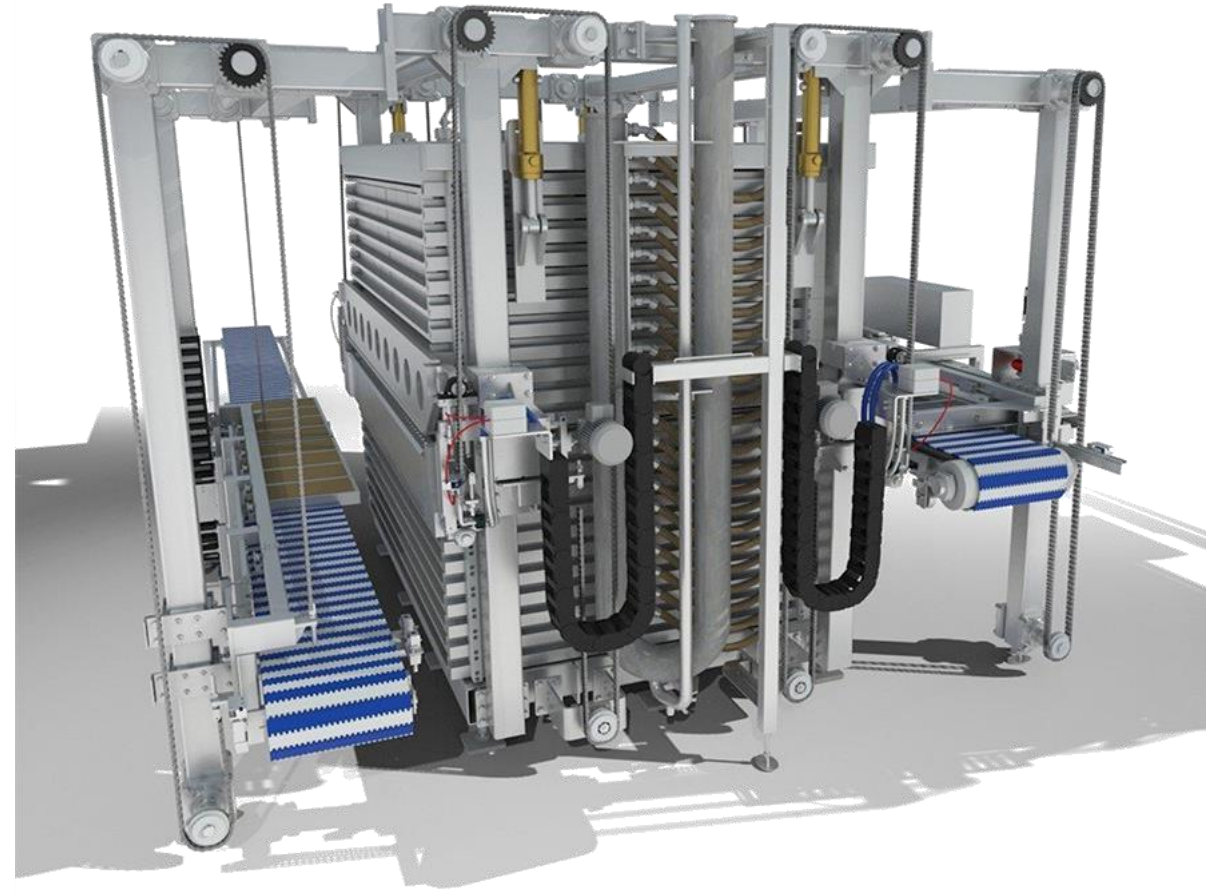





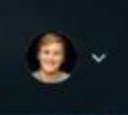

OPTIMAR

COMMANDER



Map

List

A vertical sidebar menu with two options: 'Map' with a globe icon and 'List' with a list icon. The 'Map' option is highlighted with a light blue background.

☰ Blomvik

Veidar

Operations Equipment Notes Reports

STORAGE

Filled

70%

Total

287 t

SPECIES IN STORAGE

Cod

28 t

Redfish

231 t

Haddock

210 t

Other

19 t

Distribution history



SETTING AND BAITING



Baited

2853 hooks 96%



HAULING



Recognition

56 /80
fish/min

PACKING



V3 robot
3 /4
blocks/min



Palleting
2 /4
pallets/h

HOTEL



Filling degree

70%





Peder Stette



fish handling
with **care**